



Ercole Litter Bin

The Ercole Litter Bin is constructed from a cylindrical body which is formed from welded drawn steel rods. The rods are fixed to a robust sandblasted concrete base with steel bolts which makes the litter bin extremely stable with the option of anchoring the bin to the ground through a central hole, with the relevant fixing or anchor. The opening of the lid, available as a ring or with a cover, also with an optional ashtray with anti-theft cable, is ensured through the centrally aligned triangular key locking system. Inside the litter bin is the galvanised steel sheet liner complete with galvanised steel handle.

Specification

Materials

Body - powder coated steel

Dimensions

H: 785/945mm
W: 400mm
D: 400mm

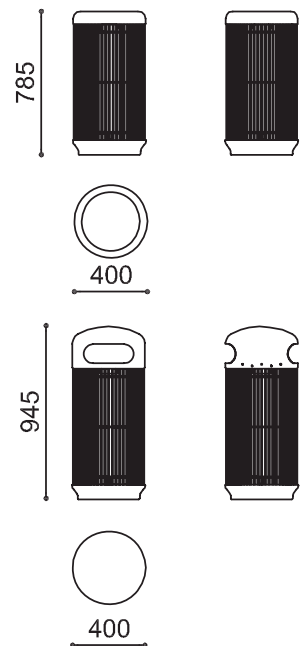

(Technical Drawings for variants available on request)

artform
urban furniture