

Onice Planter

The Onice Planter is made using a binding compound of granite or coloured marble aggregate which is bushhammered around the edges and polished to a shine on the upper side.

The planters are offered in three sizes and have a 40x50mm section recess which has been designed to facilitate cleaning the surrounding area. Inside there are 3 galvanised eyebolts for handling.

Each planter can hold a permanent 50L to 100L water reserve.

The two larger sizes can be supplied with a circular, decorated thick steel sheet bench which is welded to thick double steel supports and twenty intermediate strengthening ribs. The inner and outer external edge is pressed steel.

The bench is fastened to the planter by sixteen steel screw anchors.

All material is hot dipped galvanised and powder coated, a variety of colours available.

The surface is protected by special satin opaque varnish.

Materials:

Planter - reconstituted marblestone/granite

Seat - powder coated steel

Dimensions

Small

H: 480 x Dia: 800mm

Medium

H: 620 x Dia: 1200mm

Large

H: 760 x Dia: 1500mm

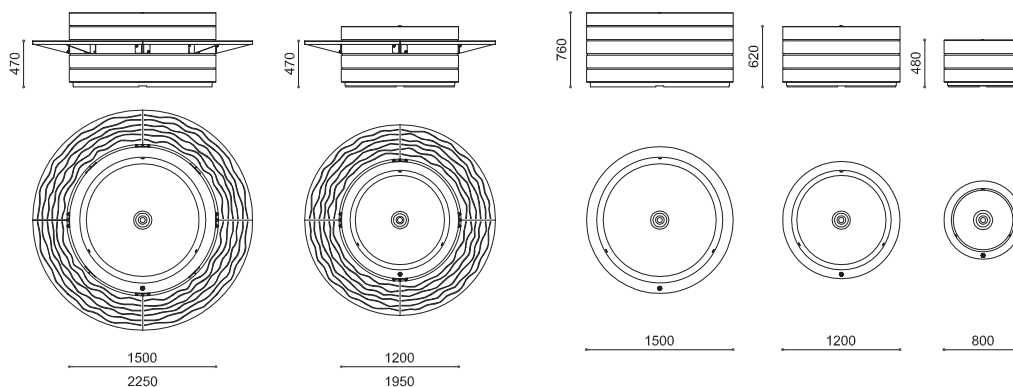

(Technical Drawings for variants available on request)

